

A Modest 45-Foot DX Vertical for 160, 80, 40 and 30 Meters

If it's DX you want, this low-angle radiator will put it in your lap! Build it now and collect DX dividends this winter.

By Wayne H. Sandford, Jr.,* K3EQ

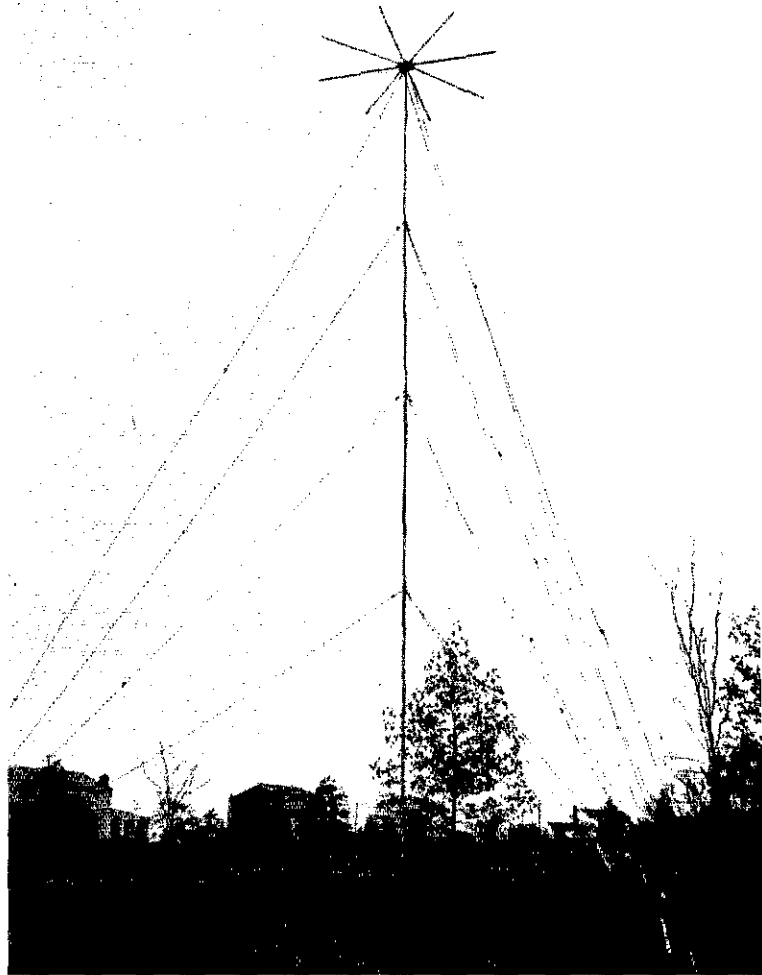

Twenty years is a long time to be away from Amateur Radio! But, fortunately, when I returned to the airwaves in December 1975, the season for working distant stations had arrived. The allure of finding signals from other continents became almost magnetic, and before long, the DX bug had clearly bitten me again. With a 120-watt homemade cw rig and a 120-ft end-fed wire strung 28 ft above the ground,¹ I worked what countries I could while being constrained by the nature of this "sky wire." Without question, a better antenna was needed for my DXing efforts. What to do?

Improvements began with the construction of a 36-ft wooden tower I built to support a 2-element quad for 10, 15 and 20 meters. From the top of this tower, I hung a 40-meter vertical antenna, followed by the installation of twenty-four 50-ft radials. DXing on 40 meters improved noticeably as a result of this effort.

For awhile I was satisfied to leave my 80-meter inverted L alone. It was strung between the quad tower and a mast supporting one end of my end-fed wire. Admittedly, results with this antenna were mediocre. During the winter of 1979-80, as I approached the requirements for Five-Band DXCC on all bands except 80 meters (only 50 confirmed), I began to think about better DX antennas for the lower frequencies.

Research

I looked through back issues of *QST* and other publications for antenna articles: A *QST* article by Hollander² triggered thoughts of constructing a multi-band vertical antenna. Radiation patterns of 1/8-, 1/4-, 1/2- and 5/8-wavelength vertical antennas indicate that an antenna having this configuration would give low-angle radiation on four bands. Calculations indicated these fractional lengths could be applied to 160-, 80-, 40- and the new 30-meter band that will become available sometime during 1982. A 5/8-wavelength vertical antenna for 30 meters

is nearly 60 ft high. A half wavelength for 40 meters is 70 ft; 1/4 wavelength for 80 meters is 70 ft; and 1/8 wavelength on 160 meters is 68 ft. Therefore, if a pole 60 ft high were used, series inductance could be added to obtain the required electrical length on all four bands. But as much as I desired to have a vertical antenna 60 ft tall or greater, I decided to see if an antenna as short as 40 ft would serve my purpose. Furthermore, although not too much has been said by the neighbors about the 2-element quad, I feared that a 60-ft vertical antenna might stimulate a barrage of adverse comments!

After pondering the matter for some time and studying radiation resistance and reactance plots for vertical antennas,³ the solution of the problem came into focus. For an antenna shorter than 60 ft some form of loading was needed. A "top hat" provides an efficient means for doing this.⁴

This multiband antenna should first be calculated for 5/8 wavelength on 30 meters. It will give an almost perfect match to a 50-ohm line by adding a small

*P.O. Box 395, Warrington, PA 18976

Notes appear on page 31.

Table 1

Dimensions for Optimum Height of the Vertical Radiator

Radiator Height (ft)	Top-hat dia (ft)	Calculated Heights for 10.125 MHz (Deg.) (Sum = 225 Deg.)			Calculated Heights for 7.025 MHz (Deg.)			Calculated Heights for 3.525 MHz (Deg.)			Calculated Heights for 1.8125 MHz (Deg.)		
		Height	Top Loading	= Sum	Height + Top Loading	= Sum	Height + Top Loading	= Sum	Height + Top Loading	= Sum			
43	11	159.5	65.5	110.6	56.7	167.3	55.5	37.4	92.9	28.5	21.4	49.9	
44	9.6	163	62	113.2	52.6	165.8	56.8	33.2	90	29.2	18.6	47.8	
45	8.2	166.9	58.1	115.8	48.1	163.9	58.1	29.2	87.3	29.9	16	45.9	

Meters = feet × 0.3048

Table 2

How Top-Hat Loading is More Effective on Lower Bands in Increasing Effective Height

F (MHz)	Top Loading (Deg.)	Top Loading (ft)	Ant. Effect. Height (ft)	Ant. Effect. Height (λ)
1.8125	18.6	28	72	0.133
3.525	33.2	25.7	69.7	0.249
7.025	52.6	20.5	64.5	0.456
10.125	62	16.7	60.7	0.625

Meters = feet × 0.3048

inductance in series with the antenna at the feed point, then tuning out the capacitive reactance with a shunt inductor. If the antenna is a half-wavelength long at 40 meters (the length at which reactance is zero), it could be adjusted easily by using a parallel-tuned tank in series with the ground lead, and by tapping the feed line at a point on the tank just a few turns up from the ground end. The tap and tuning adjustments are arranged to give the best match. It seemed that if the antenna were 1/4 wavelength long at 80 meters, it could be increased in length to provide a 50-ohm feed point by means of a small series inductor and a shunt capacitor to tune out the reactance. In addition, since it would be considerably shorter than 1/4 wavelength on 160 meters (on the order of 1/8 wavelength) it could be made to look like a 1/4-wavelength antenna by adding series inductance to ground. Matching could be effected by tapping the line a few turns up on the coil. Many dyed-in-the-wool DXers would not consider a 1/8-wavelength vertical antenna, but Sevick³ has shown that this can be an efficient radiator when used with an effective ground system and a low-loss, base-loading inductor.

Design Procedure

I could not remember having seen details of vertical antennas that explained

how to calculate the effect of the "top hat." But in past issues of *QST* I found an article by Schulz,⁴ which was just what I needed. Although his design was for a 1/4-wavelength antenna, the equations are presumed applicable for calculating the "top-hat" effects on 1/2- and 5/8-wavelength antennas. Calculations with his equations indicated that a 44-ft vertical antenna loaded by a 9.6-ft diameter "top hat" would give the results I wanted. My aim was to have a vertical antenna that would be 5/8 wavelength on 30 meters, 1/2 wavelength on 40 meters, 1/4 wavelength on 80 meters and 1/8 wavelength on 160 meters. Table 1 shows calculated electrical lengths and required "top-hat" diameters for vertical radiators from 43 to 45 ft high, showing that the 44-ft height is about right to give the required four-band performance. Table 2 shows that the "top hat" is more effective in increasing the length of the radiator as the frequency goes down.

Since this design promised a high degree of success, the preliminary circuit (Fig. 1) was prepared. A parts list was compiled (Table 3), and material collection was begun.

Construction

Purchases for the project included a 40-ft telescoping TV mast (its extended length turned out to be 38.5 ft) and a 6-ft galvanized fence post, which would just fit inside the lower mast section. With 6 in. of the post telescoped inside the mast,⁷ the overall length was the required 44 ft. To secure the mast to the fence post, two slits were made in the lower section of the mast with the aid of a hacksaw. A stainless-steel radiator hose clamp and a 1/4-20 bolt, 2-1/2 in. long, were used to clamp the mast firmly to the fence post.

The eight-spoke "top-hat" is constructed in a manner similar to that used by Hollander.⁸ There are eight 5-ft lengths of 1/2-in. diameter conduit fastened to an 11-in. square, 1/8-in. thick aluminum plate. The spokes are held firmly against the plate by means of 6-32 stainless-steel hardware. Aluminum angle stock is used to fasten the plate to the top of the upper

mast section. This stock, which is 1/8 in. thick by 1-1/2 in. wide, is cut into four 1-in. lengths. Two 1/4-20 stainless-steel bolts, 2 in. long, are used to fasten the angles to the upper mast section. I suggest the use of lock washers in all cases where the bolts are used. Good electrical contact can be assured by connecting all "top-hat" radials together and to the mast with 1/4-in. wide braid using stainless-steel, self-tapping screws. Three 48-in. long heavy-duty, screw-in steel anchors are used for the guy points. They are located 25 ft from the tower base. Four sets of guys are used. They are made from no. 12-1/2-gauge steel wire. A total of 42 egg insulators are installed to break the guys into lengths no longer than 19 ft. The base of the mast sits on a 7-in high, heavy-duty standoff insulator, which in turn rests on a 6-in. diameter concrete base that is 3 ft deep, with 4 in. protruding above ground.

Installation of the Mast

First, stand the mast upright and attach the lower set of guys to the anchors. The three top sections of the mast are pushed up from a ladder resting against the mast. Proceed by attaching the next set of guy wires to the anchors. The ladder is then extended to the second guy level, and the upper section is pushed up next. A piece of 1/4-in. braid is fastened across the joint between the top and second section of the mast, using self-tapping, stainless-steel screws. Follow this by pushing the second and top sections up together. Next, a strap is connected across the other two joints to ensure good electrical contact. Complete this part of the installation by connecting all guys to the mast, then adjust them so that the mast stands vertically.

All tuning components are mounted in a fiberglass box. Fig. 2 shows the open tuning box and components. Fig. 3, a photograph of the base of the antenna, shows how the box is attached to the 3/4-in. galvanized water pipe ground rod, and how the radial wires are terminated on a square aluminum plate (similar to the method used by Sevick).⁹ The plate is fastened to the ground rod with aluminum angle brackets, stainless-steel hardware

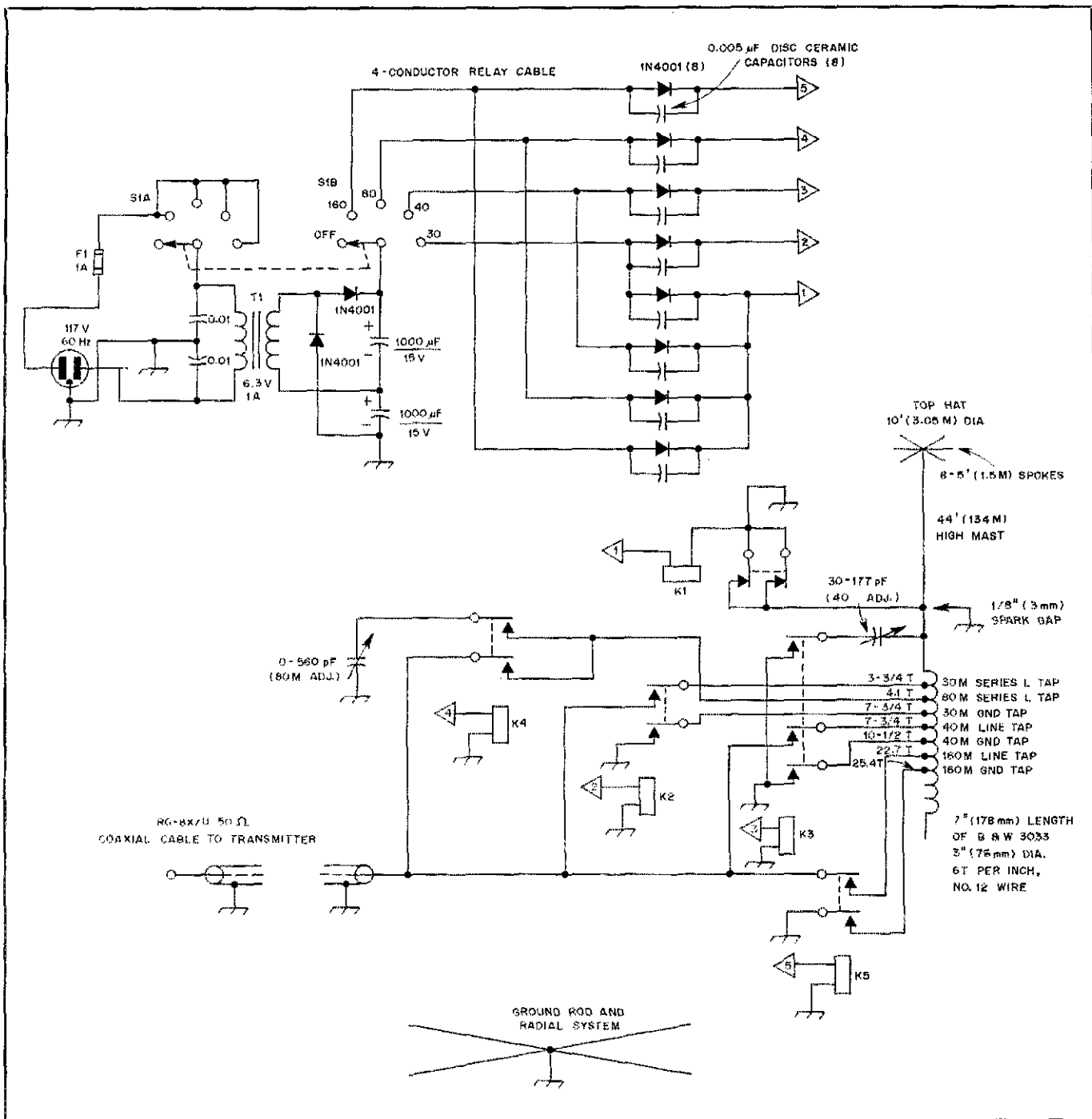

Fig. 1 — Schematic diagram for the K3EQ 160-, 80-, 40- and 30-meter vertical antenna. The circuit for remote band switching is included. There are 52 radials and a ground rod in the system. Low-angle radiation makes this an effective DX antenna.

and a stainless-steel hose clamp. All four corners of the aluminum plate are connected to the ground feedthrough in the bottom of the tuning unit with heavy copper braid. This insulator, as well as the one for the lead going to the base of the mast, is sealed against moisture by applying silicone compound. The relay control cable and the 50-ohm coaxial line enter the bottom of the tuning box through small holes that ensure a snug fit. The completed antenna, as shown in the photograph, has the capacitance hat

resting atop the mast. The mast is stabilized by careful positioning of the guy wires. A wooden fence is placed around the base of the mast to help protect people and animals from possible rf burns.

Radial System

Installation of the mast took place during the driest Pennsylvania summer in 15 years. As fall approached, the soil was still too hard to bury the radials, so they were laid on the surface. Each wire was stretched tightly and fastened with several

6-in. lengths of heavy bus wire, which had been formed into hooks. When rain eventually fell, the radials were buried 2 to 3 in. in the ground.

All radials are 100 ft long except those toward the sides of the lot (which is only 150 ft wide). One side has 70-ft radials, while the other has 80-ft radials. Some 4800 ft of wire makes up the 52 radials. I used insulated hookup wire, but aluminum clothesline¹⁰ or galvanized electric fence wire is satisfactory.

According to Stanley,¹¹ the efficiency

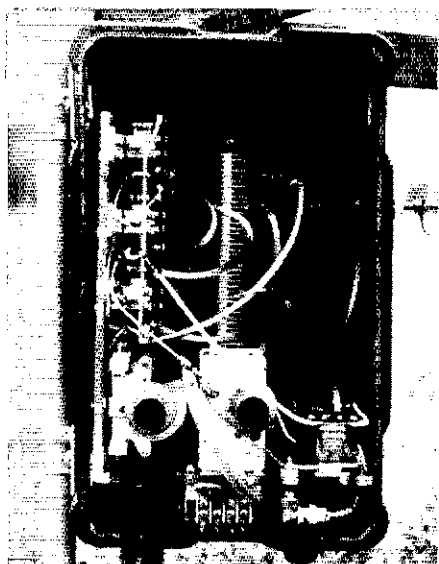

Fig. 2 — A view of the vertical antenna tuning network. Components are mounted on a framework of 1/4-in. thick Plexiglas, which slides into the fiberglass box.

of a 160-meter antenna might be improved by using more or longer radials. For the other bands, however, not much improvement is likely to be achieved by increasing the lengths or adding radials. For 160 meters, the radials are only 0.184 wavelength, but for 80 meters they are a respectable 0.352 wavelength long. Ground losses are probably on the order of 2 dB on 40 meters and about double that on 160 meters. Table 4 is a chart of the wavelengths of the 100-ft radials versus frequency.

Tuning

Tune-up is done on 160 meters first, then progressively on the higher bands. I used the K4KI¹² tune-up bridge and a

Table 3 Shopping List

- 1 — telescoping TV mast, 40 ft long, Montgomery Ward no. 83A19735R, \$39.95.
- 1 — galvanized fence post, 6 ft long, 2-in. dia., \$6.
- 4 — lengths of thin-wall conduit, 10 ft long, 1/2-in. dia. Each length is to be cut into 5-ft sections. Montgomery Ward no. Z83A1004R, size no. 2, \$1.89 ea.
- 1 — length of 3/4-in. galvanized water pipe for ground rod, 10 ft long, Montgomery Ward no. 81A40103R, \$12.
- 2 — rolls of no. 12-1/2 gauge galvanized steel wire for guys, Sears no. 32H10125, \$6.29 ea.
- 3 — earth anchors, screw type, 48-in. long, Sears no. 32H21946C, \$7. ea.
- 42 — strain insulators for guy wires, Radio Shack no. 270-1518. Price with 10% quantity discount, \$13.04.
- 120 ft (36.5m) RG8X-50 coaxial cable available from Texas Towers, Plano, Texas, \$18.
- 120 ft four-conductor control cable for relay circuit, gray vinyl jacket. Sold by Fair Radio Sales, Lima, Ohio, \$14.40. A substitute would be TV rotator cable, Sears no. 57H6732, 10¢ per foot.
- 5000 ft no. 18 vinyl-covered hook-up wire for radials, sold by Fair Radio Sales, \$75. A less expensive (but less durable) substitute is no. 17 gauge galvanized steel wire. This is avail-

- able from Sears, no. 32H22056C, at \$16 per roll. Each roll has 2640 ft of wire.
- 1 — B & W coil no. 3033, 10 in. long, 3-in. dia, no. 12 wire, 6 tpi, available from Barker and Williamson, 10 Canal St., Bristol, PA 19007, \$7.97.
- 1 — fiberglass case, 14-1/2 x 14 x 4-1/4 in., available from Fair Radio Sales, \$5.
- 5 — relays, dpdt plus spst; N.O., 12 V dc, Leach no. 1077, available from Fair Radio Sales, \$2 each.
- 1 — variable capacitor, 30-177 pF with both sections in parallel, 0.094-in. air gap. Fair Radio Sales, no. C-221/T-195, \$3.95.
- 1 — variable capacitor, 0-563 pF, 0.03-in. air gap, Fair Radio Sales, no. 76348-C, \$2.95.
- 2 — cone-style feedthrough insulators, Fair Radio Sales, no. 3G584IN-84, 25¢ each.
- 1 — standoff insulator, 7-in. x 1-1/4 in. dia, Fair Radio Sales, no 5970-405-8992, \$4.

Miscellaneous: parts for control box purchased from Radio Shack, \$20.
Stainless-steel hardware from Elwick Supply Co., Somerdale, New Jersey, \$12.
Aluminum angle stock and 1/8-in. aluminum plates from local metal suppliers, hose clamps, ready-mix concrete, copper shielding and braid, \$10.

Note: The total cost was approximately \$300 at the time the antenna was built. It is reasonable to expect the present costs to be about 10% higher. By "scrounging" parts from your junk box, and from friends and flea markets, the cost can be reduced.

dummy load at the base of the antenna to make the adjustments. My transmitter was in the second-floor shack. I should have carried it to the base of the antenna to make the matching process easier. Finding the correct coil taps for 160 meters while using the bridge seemed almost impossible. By tightly coupling a grid-dip oscillator to a two-turn link in the ground lead, the correct ground tap point was located. The line tap was then positioned properly with the aid of the tune-up bridge. Adjustments for the other

bands followed without difficulty. The required inductances were close to the calculated values. Fig. 4 shows an SWR plot for the antenna. Refer also to Table 5.

This data was obtained in the shack at the end of the 120-ft length of RG-8X coaxial feed line. The SWR might be brought closer to 1:1 on 30 meters by further adjustments for that band. After the tap points on the coil were found, I soldered miniature alligator clips to the coil. A purist might prefer to remove the

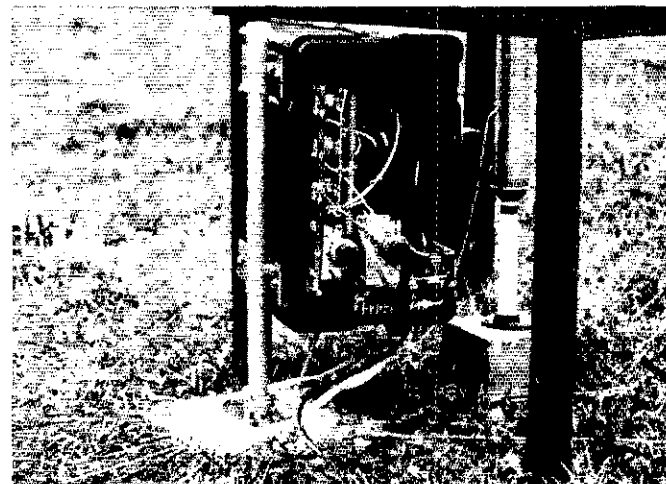

Fig. 3 — Base of the vertical antenna with the tuning-component box mounted on the ground rod. The radials terminate on a square aluminum plate.

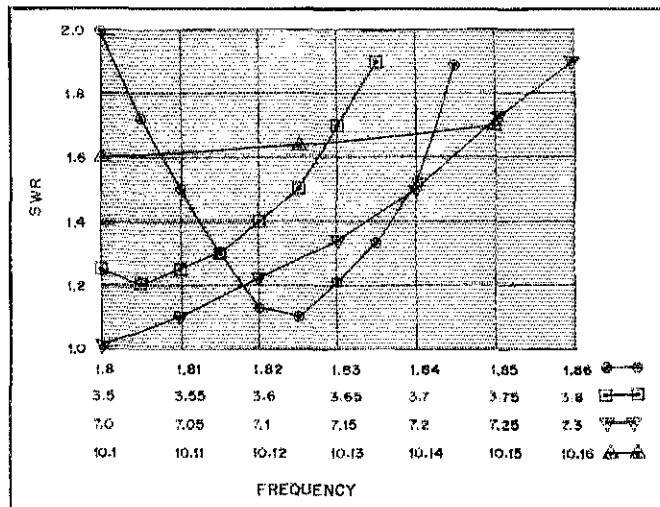

Fig. 4 — SWR curves for the K3EQ vertical antenna. See Table 5 for related information.

clips and solder the braid directly on the coil. I left the clips there to facilitate future adjustments.

The antenna is resonant outside the low ends of the 30- and 40-meter bands. This apparently results from the extra foot or so of wire from the base of the mast to the tuning box and ground. Additionally, I did not cut the "top hat" to the calculated 9.6-ft diameter, but left it at 10 ft. Shortening the mast 1 foot should bring the resonant points within the 30- and 40-meter bands. If additional correction is needed, then remove 2.5 in. from each of the "top-hat" spokes. This change may require repositioning of the taps from the points indicated on the schematic diagram (Fig. 1).

Afterthoughts

Phone operators may think this article has nothing to offer them. Therefore, I went through an exercise to determine the optimum configuration to cover the new 30-meter band and the 160-meter band, and also to allow adjustment for the lowest SWR at the center of the 40- and 75-meter phone bands. To accomplish this, the mast must be lengthened to 47.5 ft, and the top-hat diameter reduced to 5.8 ft. Table 6 charts the calculations that lead to this conclusion.

Of course the tuning network would allow this configuration to be tuned to the 40- and 80-meter cw bands by those operators who might like to tune the antenna to any part of these bands. For 80-meter cw, more series inductance would be needed for the 44-ft version. For 40-meter cw, some series inductance would have to be inserted between the mast base and the parallel-tuned tank. This requires only moving all three 40-meter coil taps down the coil a few turns. Proper adjustment for operation anywhere in the 40- or 80-meter bands can be made with this configuration.

The full 40-meter band could be covered with an SWR of 1.4:1 or less if this matching network is tuned for the lowest SWR at 7.15 MHz. This can be

verified by extrapolating the SWR curves of Fig. 4. Likewise, it appears that if the configuration were tuned for the lowest SWR at 3.8875 MHz, all of the 75-meter phone band could be covered with an SWR of 1.7:1 or less.

Conditions were not favorable for evaluating its DX qualifications when I conducted tests with this antenna. Results obtained were nevertheless gratifying. Europe and South America have been worked with very good reports on 80 and 40 meters. On 160 meters, with 100-watts input to a TX4C, I received an RST 589 report from KP2A followed by a 549 from VP9KA. To the west, my circle of contacts has been from Minnesota (559) through Wisconsin (579), Iowa (559), Kansas (539) and Arkansas (559). A 339 report came from New Mexico, and a station in Florida gave me a 579. All of these contacts were made in the early evening.

I have shown none of the math calculations; only the results in the form of tables. Amateurs who desire a copy of these calculations should send a request to the ARRL Technical Department. Enclose an s.a.s.e. and \$1.

If you wish to enhance your DX capabilities on the lower bands without erecting a "monster antenna," to be prepared for the new 30-meter band when it becomes available or to try the recently expanded "top band" for the first time, then this may be just the antenna for you. Build it, and you'll be ready for some good DXing!

Notes

- ¹meters = feet \times 0.3048.
- ²D. Hollander, "A Big Signal from a Small Lot," *QST*, April 1979, pp. 32-34.
- ³Editors of *73 Magazine*, *The Giant Book of Amateur Radio Antennas* (Summit, PA: Tab Books).
- ⁴J. Sevick, "The W2FMI Ground-Mounted Short Vertical," *QST*, March 1973, pp. 13-18, et al.
- ⁵J. Sevick, "Short Ground-Radial Systems for Short Verticals," *QST*, April 1978, pp. 30-33.
- ⁶W. Schulz, "Designing a Vertical Antenna," *QST*, Sept. 1978, pp. 19-21.
- ⁷millimeters = inches \times 25.4.
- ⁸See note 2.
- ⁹See note 4.
- ¹⁰[Editor's Note: In regions where the soil has a high acid or alkaline content, rapid disintegration of aluminum wire will occur, sometimes within a few months. Neoprene-jacketed no. 8 aluminum wire (sold by Sears as overhead power wiring for outdoor applications) is relatively inexpensive and is highly resistive to corrosion.]
- ¹¹J. Stanley, "Optimum Ground Systems for Vertical Antennas," *QST*, Dec. 1976, pp. 13-15.
- ¹²W. Vissers, "Tune Up Swiftly, Silently and Safely," *QST*, Dec. 1979, pp. 42-43.

Table 5
Data for SWR Curves in Fig. 4

Frequency (MHz)	SWR
1.8	2.0
1.805	1.72
1.81	1.5
1.815	1.3
1.82	1.13
1.825	1.1
1.83	1.21
1.835	1.33
1.84	1.52
1.845	1.89
3.5	1.25
3.525	1.2
3.55	1.25
3.575	1.3
3.6	1.4
3.625	1.5
3.65	1.7
3.675	1.9
7.0	1.01
7.05	1.1
7.1	1.22
7.15	1.34
7.2	1.5
7.25	1.72
7.3	1.9
10.1	1.6
10.125	1.64
10.15	1.7

Table 4
Length of Ground Radials in Wavelengths Versus Frequency

F (MHz)	100-ft (30-m) Radials (length in λ)
1.8125	0.184
3.525	0.357
7.025	0.712
10.125	1.029

Table 6
Chart for Selecting Optimum Radiator for Phone Bands (7.225 and 3.8875 MHz)

Radiator Height (ft)	Top Hat Cap (pF)	Top Hat Dia (ft)	Calculated Heights for 10.125 MHz (Deg.)		Calculated Heights for 7.225 MHz (Deg.)			Calculated Heights for 3.8875 MHz (Deg.)			Calculated Heights for 1.8125 MHz (Deg.)		
			Height	Top Loading	Height	Top Loading	Sum	Height	Top Loading	Sum	Height	Top Loading	Sum
47	49	6	174.3	50.7	124.39	41.08	165.47	66.93	25.13	92.06	31.2	12.27	43.47
47.5	46	5.8	176.17	48.83	125.7	39.2	164.9	67.64	23.69	91.33	31.54	11.56	43.1
48	43	5.3	178.02	46.98	127	37.36	164.36	68.35	22.33	90.68	31.87	10.84	42.7
49	37.7	4.75	181.73	43.27	129.68	33.88	163.56	69.78	19.86	89.64	32.53	9.56	42.09

Note: Subtract length of lead into tuning unit plus ground lead from calculated radiator height.